

# Expansion tanks for pressurized systems SolarPlus

259 series

**CALEFFI  
SOLAR**



## General

Modern solar heating systems can reach temperatures of up to 385°F during inactivity. The result is the vaporization of the solar liquid and extreme temperatures in the solar circuit, up to the solar station. This damages parts of the system, including pumps, connection joints and the diaphragm in the expansion tank. Furthermore, in the event of prolonged heat absorption, for example in the summer, when on vacation or if the electricity is out, the pressure of the solar system can increase to the point of activating the safety relief valve. In order to support the highest possible inactivity temperatures, the special heat-resistant diaphragm in the SolarPlus expansion tank can withstand temperatures up to 210°F.

## Function

The diaphragm pressure expansion tank ensures that the system pressure does not exceed or drop below the limits established in the system design. The diaphragm divides the space inside the tank occupied by the pre-charged gas and the solar fluid. When the volume of the solar fluid expands because of the heat, the diaphragm stretches into the gas chamber. As a result, the space available for the solar fluid increases and the pressure inside the system remains constant at the designed value. When the volume of the solar fluid decreases because of cooling, the diaphragm returns to the correct initial pre-charged pressure.

## Product range

Code 259 series SolarPlus expansion tanks for pressurized solar heating systems \_\_\_\_\_ sizes 3, 5, 7, 9, 13 gallons

## Technical specifications

Materials: - body:	welded steel	System temperature range:	15...250°F (-10...120°C)
- coating:	epoxy paint	Max. diaphragm temperature:	210°F (100°C)
- diaphragm:	EPDM	Max. working pressure:	150 psi (10 bar)
Medium:	water, glycol solutions	Pre-charged pressure:	35 psi (2.5 bar)
Max. percentage of glycol:	50%	Connection:	3/4" M

## Dimensions

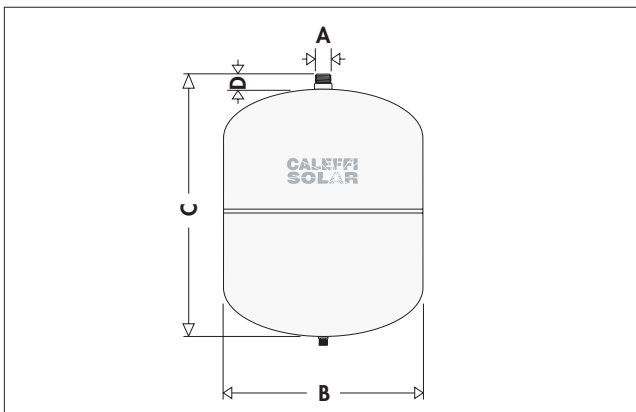

Code	A	B	C	D	Size (gal)
250 012	3/4"	10 5/8"	10 5/8"	3/4"	3
250 018	3/4"	10 5/8"	13 3/4"	3/4"	5
250 025	3/4"	11 7/8"	15 1/2"	3/4"	7

## Dimensions

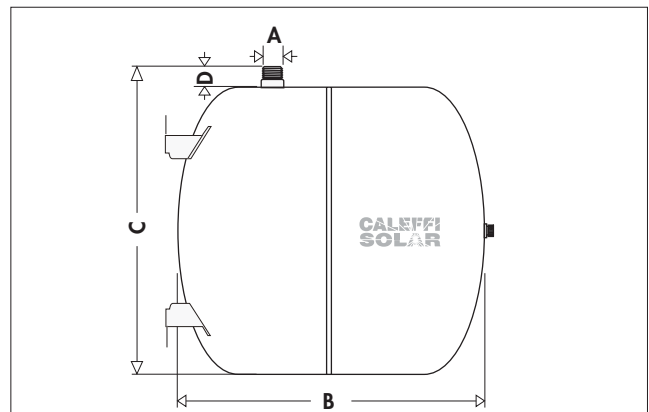

Code	A	B	C	D	Size (gal)
259 035	3/4"	15 3/4"	16"	1"	9
259 050	3/4"	21 1/8"	16"	1"	13

Mounting feet for wall installation.

## Installation

The expansion tank can be installed after the flow check valve on the outlet side of the circulation pump, between the solar collector (exit pressure), or it can be on the inlet side of the circulation pump (entrance pressure). Since there can be no check valve between the collector and the expansion tank, the expansion tank should be installed on the outlet side of the pump (exit pressure).

## Accessories

A expansion tank connection kit, consisting of a flexible stainless steel hose, a double automatic shut-off valve, wall bracket and mounting hardware, helps reduce installation time and provides suitable mounting.

### Code: 255001

Max. working pressure: 150 psi (10 bar).  
 Max. check valve working temperature: 250° F (120°C).  
 Hose length: 20 in. (500 mm).  
 Connections: 3/4" straight.

Bracket for expansion tank with a maximum capacity of 7 gallons.

